

Momentary Solid State Switch for Split Phase Motors



ON Semiconductor®

<http://onsemi.com>

APPLICATION NOTE

INTRODUCTION

In control applications for motors the choice of the solid state switch to be used is always very important for the designers: the cost, reliability, ruggedness, and ease to be driven must always be kept in mind. This is especially important in motor control circuits where the designer has to optimize the circuitry for controlling the motors in the correct and efficient way.

In the large family of electronic switches, the thyristor must be considered as a low cost and powerful device for motor applications. Thyristors can take many forms, but they have certain features in common. All of them are solid state switches which act as open circuits capable of withstanding the rated voltage until triggered. When they are triggered, thyristors become low impedance current paths and remain in that condition (i.e. conduction) until the current either stops or drops below a minimum value called the holding level. Once a thyristor has been triggered, the trigger current can be removed without turning off the device.

Because Thyristors are reliable solid state switches, they have many applications, especially as controls. A useful application of triac is as a direct replacement for an AC mechanical relay. In this application, the triac furnishes on-off control and the power regulating ability of the triac is utilized. The control circuitry for this application is usually very simple, consisting of a source for the gate signal and some type of small current switch, either mechanical or electrical. The gate signal can be obtained from a separate source or directly from the line voltage at terminal MT2 of the triac.

One of the most common uses for thyristors is to control AC loads such as electric motors. This can be done either by controlling the part of each AC cycle when the circuit conducts current (Phase control) or by controlling the

number or cycles per time period when current is conducted (cycle control). In addition, thyristors can serve as the basis of relaxation oscillators for timers and other applications.

DEFINITIONS

Split-Phase Motor. Split-Phase motors have two stator windings, a main winding and an auxiliary winding, with their axes displaced 90 electrical degrees in space. The auxiliary winding has a higher resistance-to-reactance ratio than the main winding, so that the two currents are out of phase. The stator field thus first reaches a maximum about the axis of one winding and then somewhat later in time (about 80 to 85 electrical degrees) reaches a maximum about the axis of the winding 90 electrical degrees away in space. The result is a rotating stator field which causes the motor to start. At about 75 percent of synchronous speed, the auxiliary winding is cut out by a centrifugal switch.

The below figure shows a schematic representation of a split-phase motor:

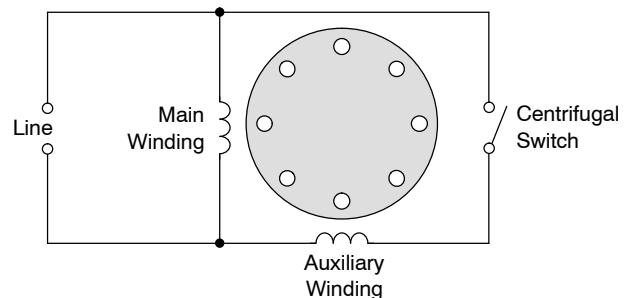

When the line voltage is applied, the current flows through both windings and the result is a rotating stator field which causes the motor to start. At about 75 percent of synchronous speed, the auxiliary winding is cut out by a centrifugal switch.

The following figure shows a conventional schematic diagram using a relay for controlling a split-phase fractional horsepower motor (the compressor of a refrigerator for example):

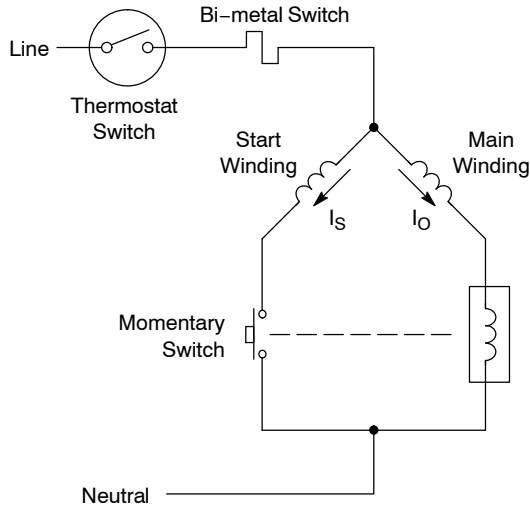

In the previous figure the thermostat-switch is controlling the working-cycle of the compressor and it is dependent on the set point of environment temperature which has to be selected according to the temperature needed. The bi-metal switch protects the compressor against overload and the relay controls the momentary switch which cuts out the starter winding once the motor has reached about 75 percent of the synchronous speed (after around 300 msec).

The below plot shows the current flowing through the compressor (1 Phase, 115Vac, 60Hz, 4.1Arms) when it starts to operate under normal conditions:

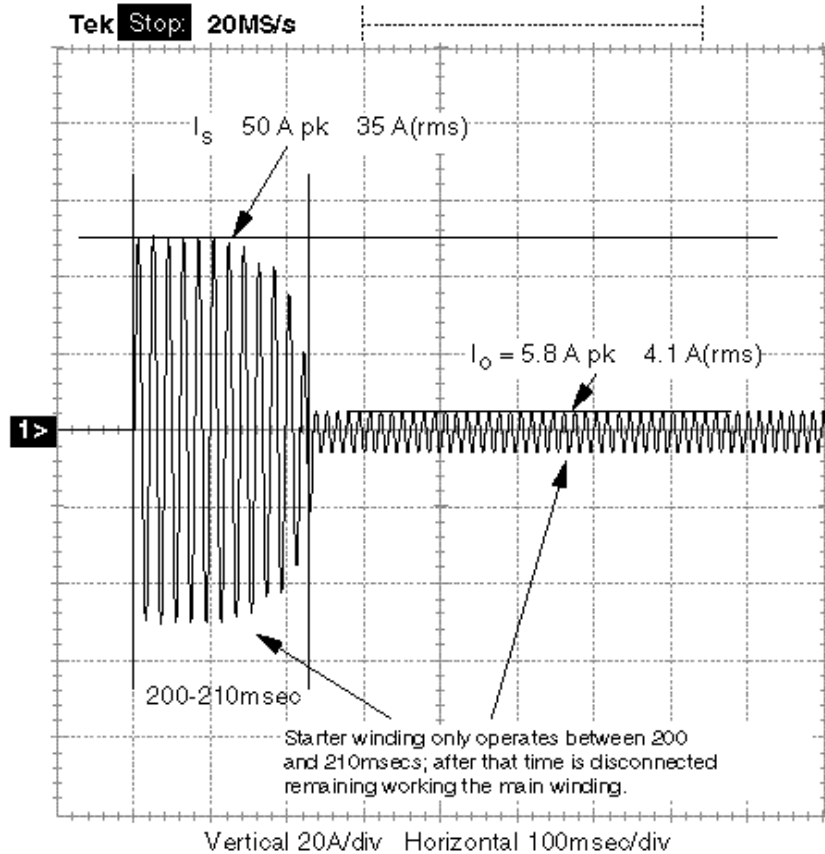

This plot shows the total current flowing through the compressor when it starts to operate and the time in which the current reaches the maximum value (I_s) due to the start of the motor. After this time (210 msec) the start winding

is cut out by the momentary switch and then the current decreases to reach the nominal current of the compressor ($I_o=4.1$ Arms).

AND8007/D

The following schematic diagrams show the way triacs can substitute for the relay and how they can be triggered by using different control options:

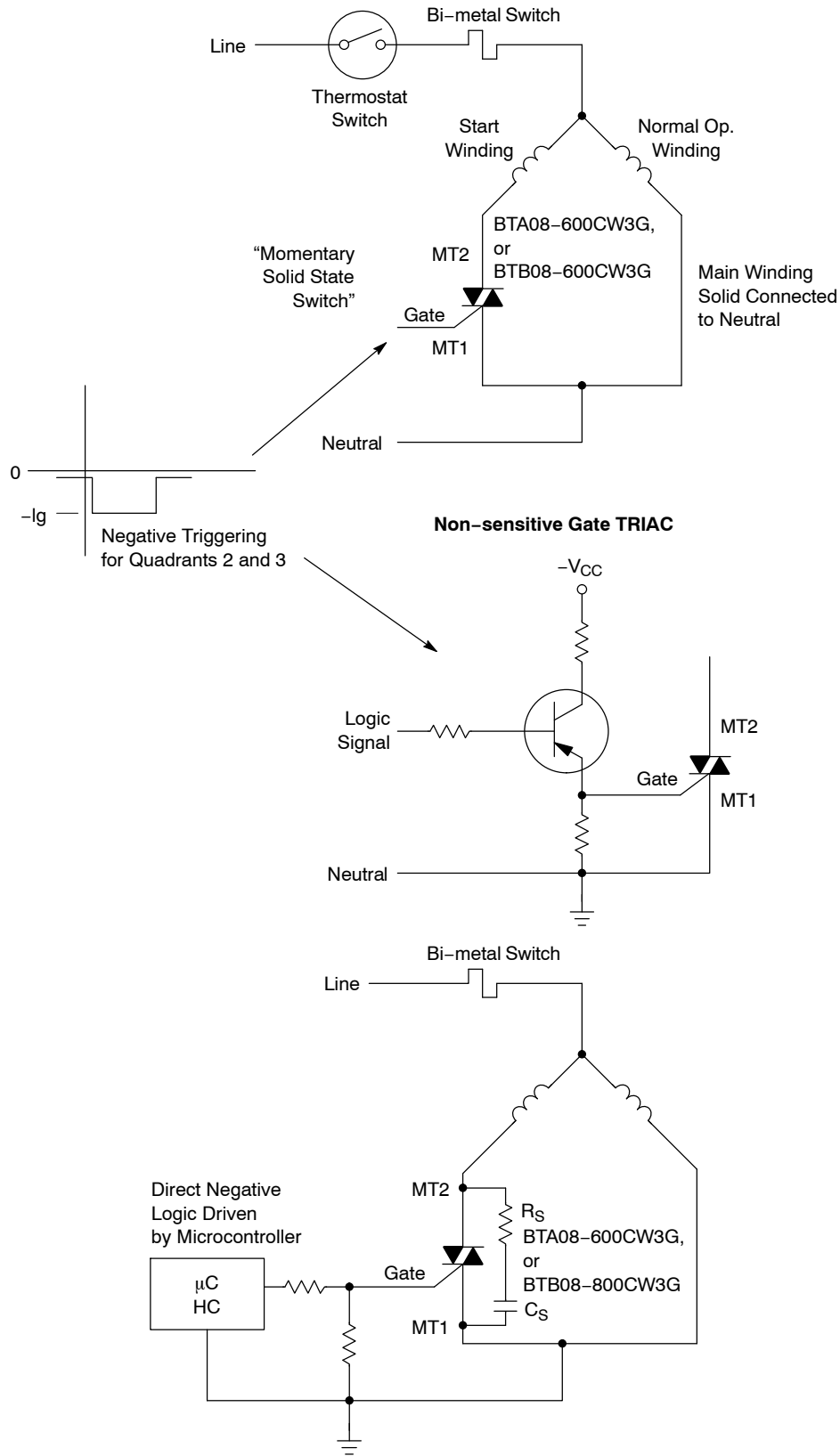

AND8007/D

In the first diagram, the triac BTA08-600CW3G or BTB08-600CW3G is making the function of the conventional relay's momentary switch, and it can be triggered by using a transistor as shown in the above schematic or through the signals of a microcontroller. Since this triac BTA08-600CW3G or BTB08-600CW3G is a snubber-less device, it does not need a snubber network for protecting itself against dV/dt phenomena.

In the second diagram the triac BTA08-600CW3G or

BTB08-600CW3G is also performing the function of the relay's momentary switch, but since this device is a sensitive gate triac, it only needs a very low I_{gt} current for triggering itself, therefore, this option is especially useful in applications where the level of the current signals are small.

On the other hand, the following figure shows a practical solid state solution for controlling the compressor with the operating characteristics mentioned previously (1 Phase, 115Vac, 60Hz, 4.1 Arms) :

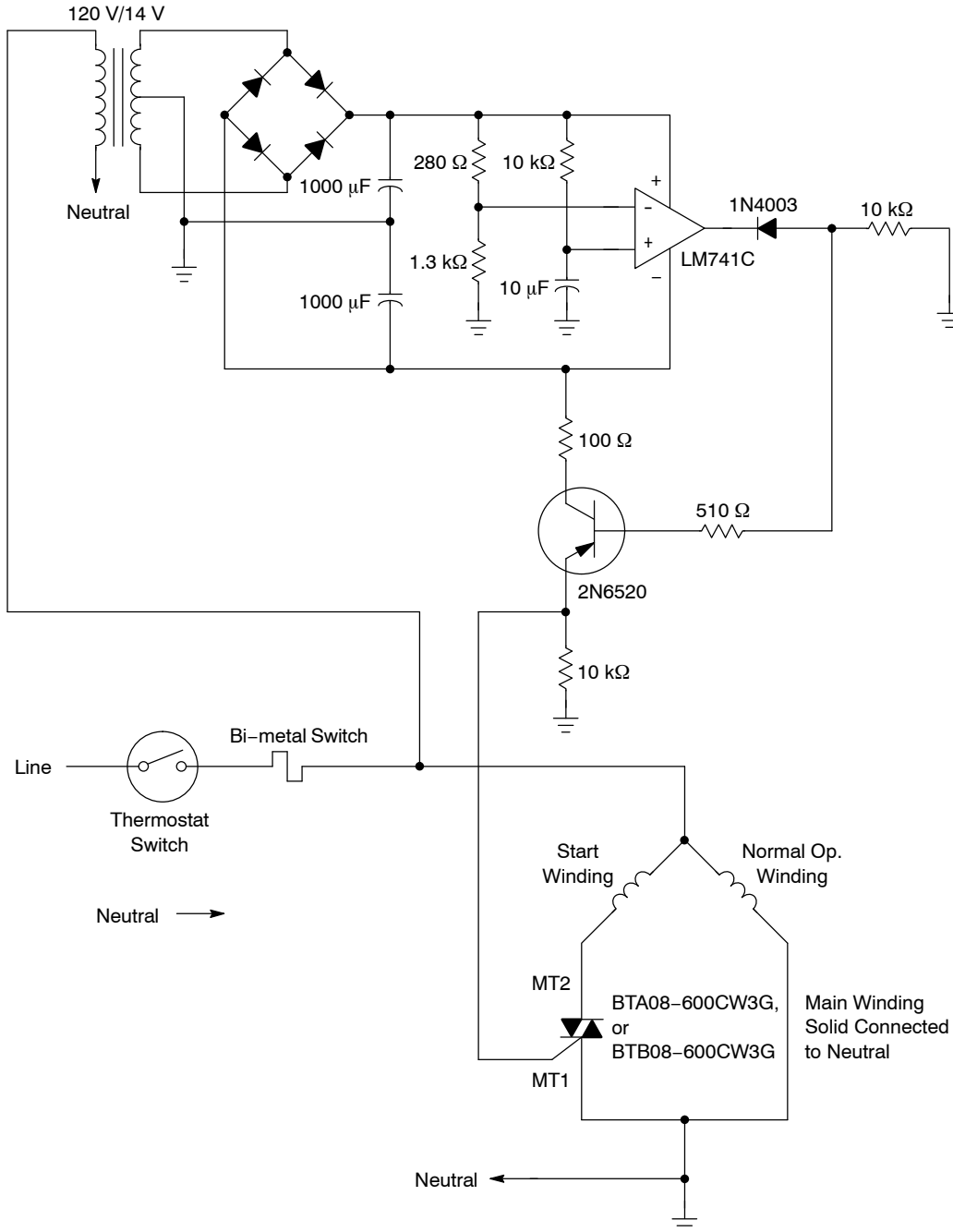

AND8007/D

When the thermostat switch is activated, the triac BTA08–600CW3G or BTB08–600CW3G turns–on and allows current flow through the starter winding. This current is around 20 Arms because at the start of the motor (see current plot shown previously), after around 210msec, the triac turns–off and blocks the current flowing through the starter winding. In that moment, the total current flowing through the motor decreases until it reaches the nominal current (4.1 Arms) and the motor continues operating until the thermostat switch is switched off.

Since the triac operates for very short times (around 210 msec), it does not need a heat sink, therefore, it can be placed on the control board without any kind of problems.

In the previous schematic diagram the triac of 8 Arms BTA08–600CW3G or BTB08–600CW3G, was selected based on the nominal and start current conditions of the compressor previously described (1 Phase, 115Vac, 60Hz, 4.1Arms). Therefore, it is important to mention that in these kind of applications, the triacs must be selected taking into consideration the characteristics of each kind of motor to

control (nominal and start currents, frequency, Vac, power, etc). Also, it is important to remember that it is not possible to have a general reference for selecting the right triacs for each motor control application.

In conclusion, the solid state solution described previously, provides a more reliable control than the conventional momentary switch controlled by a relay since the thyristors do not cause any kind of sparks when they start to operate. In addition, the total price of the electronic components do not exceed the price of the conventional relay approach.

In summary, it is also important to mention that extreme environmental temperatures could affect the functionality of this momentary solid state switch, but it is a fact that the triac solution is able to operate between 0°C to 65°C.

Another important consideration is to include in the power circuit of the motor the right overload switch in order to protect the motor and the triacs against overload phenomena.

ON Semiconductor and **ON** are registered trademarks of Semiconductor Components Industries, LLC (SCILLC). SCILLC reserves the right to make changes without further notice to any products herein. SCILLC makes no warranty, representation or guarantee regarding the suitability of its products for any particular purpose, nor does SCILLC assume any liability arising out of the application or use of any product or circuit, and specifically disclaims any and all liability, including without limitation special, consequential or incidental damages. "Typical" parameters which may be provided in SCILLC data sheets and/or specifications can and do vary in different applications and actual performance may vary over time. All operating parameters, including "Typicals" must be validated for each customer application by customer's technical experts. SCILLC does not convey any license under its patent rights nor the rights of others. SCILLC products are not designed, intended, or authorized for use as components in systems intended for surgical implant into the body, or other applications intended to support or sustain life, or for any other application in which the failure of the SCILLC product could create a situation where personal injury or death may occur. Should Buyer purchase or use SCILLC products for any such unintended or unauthorized application, Buyer shall indemnify and hold SCILLC and its officers, employees, subsidiaries, affiliates, and distributors harmless against all claims, costs, damages, and expenses, and reasonable attorney fees arising out of, directly or indirectly, any claim of personal injury or death associated with such unintended or unauthorized use, even if such claim alleges that SCILLC was negligent regarding the design or manufacture of the part. SCILLC is an Equal Opportunity/Affirmative Action Employer. This literature is subject to all applicable copyright laws and is not for resale in any manner.

PUBLICATION ORDERING INFORMATION

LITERATURE FULFILLMENT:

Literature Distribution Center for ON Semiconductor
P.O. Box 5163, Denver, Colorado 80217 USA
Phone: 303-675-2175 or 800-344-3860 Toll Free USA/Canada
Fax: 303-675-2176 or 800-344-3867 Toll Free USA/Canada
Email: orderlit@onsemi.com

N. American Technical Support: 800-282-9855 Toll Free
USA/Canada
Europe, Middle East and Africa Technical Support:
Phone: 421 33 790 2910
Japan Customer Focus Center
Phone: 81-3-5773-3850

ON Semiconductor Website: www.onsemi.com
Order Literature: <http://www.onsemi.com/orderlit>

For additional information, please contact your local Sales Representative